

# A Review on Waste Heat Recovery in Industries

Mr. Rupesh Suryavanshi<sup>1</sup>, Prof.A.D.Pitale<sup>2</sup>

*M.Tech. (Heat & Power) Student<sup>1</sup>, Assistant Professor<sup>2</sup>*

*<sup>1,2</sup>Department of Mechanical Engineering, G.H.Raisoni College of Engineering Nagpur (MH), India*

**Abstract:** This research article presents a review of various works focussed on waste heat in industry for improving energy efficiency. The different reviews based on the aspects of heat recovery and the methodologies and technologies being employed for its optimization in industries also study through literature. This work also concentrated on the different parameters governing the waste heat recovery in the industries.

## 1. INTRODUCTION

Industrial waste heat refers to energy that is generated in industrial processes without being put to practical use. Sources of waste heat include hot combustion gases discharged to the atmosphere, heated products exiting industrial processes, and heat transfer from hot equipment surfaces. The exact quantity of industrial waste heat is poorly quantified, but various studies have estimated that as much as 20 to 50% of industrial energy consumption is ultimately discharged as waste heat. While some waste heat losses from industrial processes are inevitable, facilities can reduce these losses by improving equipment efficiency or installing waste heat recovery technologies. Waste heat recovery entails capturing and reusing the waste heat in industrial processes for heating or for generating mechanical or electrical work. Example uses for waste heat include generating electricity, preheating combustion air, preheating furnace loads, absorption cooling, and space heating.

Heat recovery technologies frequently reduce the operating costs for facilities by increasing their energy productivity. Many recovery technologies are already well developed and technically proven; however, there are numerous applications where heat is not recovered due to a combination of market and technical barriers. As discussed below, various sources indicate that there may be significant opportunities for improving industrial energy efficiency through waste heat recovery. A comprehensive investigation of waste heat losses, recovery practices, and barriers is required in order to better identify heat recovery opportunities and technology needs. Such an analysis can aid decision makers in identifying research priorities for promoting industrial energy efficiency.

### *Waste Heat Recovery*

Waste heat losses arise both from equipment inefficiencies and from thermodynamic limitations on equipment and processes. For example, consider oil fired furnaces frequently used in steel melting operations. Exhaust gases immediately leaving the furnace can have temperatures as high as 2,200,400°F [1,200,300°C]. Consequently, these

gases have high heat content, carrying away as much as 60% of furnace energy inputs. Efforts can be made to design more energy efficient reverberatory furnaces with better heat transfer and lower exhaust temperatures; however, the laws of thermodynamics place a lower limit on the temperature of exhaust gases. Since heat exchange involves energy transfer from a high temperature source to a lower temperature sink, the combustion gas temperature must always exceed the molten steel temperature in order to facilitate steel melting. The gas temperature in the furnace will never decrease below the temperature of the molten steel, since this would violate the second law of thermodynamics. Therefore, the minimum possible temperature of combustion gases immediately exiting a steel reverberatory furnace corresponds to the aluminium pouring point temperature 1, 2001, 380°F [650750°C]. In this scenario, at least 40% of the energy input to the furnace is still lost as waste heat.

Recovering industrial waste heat can be achieved via numerous methods. The heat can either be “reused” within the same process or transferred to another process. Ways of reusing heat locally include using combustion exhaust gases to preheat combustion air or feed water in industrial boilers. By preheating the feed water before it enters the boiler, the amount of energy required to heat the water to its final temperature is reduced. Alternately, the heat can be transferred to another process; for example, a heat exchanger could be used to transfer heat from combustion exhaust gases to hot air needed for a drying oven. In this manner, the recovered heat can replace fossil energy that would have otherwise been used in the oven. Such methods for recovering waste heat can help facilities significantly reduce their fossil fuel consumption, as well as reduce associated operating costs and pollutant emissions. Typical sources of waste heat and recovery options are listed in Table 1.

Table 1 – Examples of Waste Heat Sources and End Uses

Waste Heat Sources	Uses for Waste Heat
<ul style="list-style-type: none"> <li>• Combustion Exhausts:</li> <li>Glass melting furnace</li> <li>Cement kiln</li> <li>Fume incinerator</li> <li>Steel reverberatory furnace</li> <li>Boiler</li> <li>• Process offgases:</li> <li>Steel electric arc furnace</li> <li>Steel reverberatory furnace</li> <li>• Cooling water from:</li> <li>Furnaces</li> <li>Air compressors</li> <li>Internal combustion engines</li> <li>• Conductive, convective, and radiative losses from equipment:</li> <li>HallHèroult cells</li> <li>• Conductive, convective, and radiative losses from heated products:</li> <li>Hot cokes</li> <li>Blast furnace slags</li> </ul>	<ul style="list-style-type: none"> <li>• Combustion air preheating</li> <li>• Boiler feed water preheating</li> <li>• Load preheating</li> <li>• Power generation</li> <li>• Steam generation for use in:</li> <li>power generation mechanical power process steam</li> <li>• Space heating</li> <li>• Water preheating</li> <li>• Transfer to liquid or gaseous process streams</li> </ul>

Combustion air preheat can increase furnace efficiency by as much as 50%. Another advantage of waste heat recovery is that it can reduce capacity requirements for facilities’ thermal conversion devices, leading to reductions in capital costs. For example, consider the case of combustion exhaust gases used to heat building air for space heat. In addition to replacing purchased fuels, the recovered waste heat can potentially eliminate the need for additional space heating equipment, thereby reducing capital and overhead costs.

**2. FACTORS AFFECTING WASTE HEAT RECOVERY FEASIBILITY**

Evaluating the feasibility of waste heat recovery requires characterizing the waste heat source and the stream to which the heat will be transferred. Important waste stream parameters that must be determined include:

These parameters allow for analysis of the quality and quantity of the stream and also provide insight into possible materials/design limitations. For example, corrosion of heat transfer media is of considerable concern in waste heat recovery, even when the quality and quantity of the stream is acceptable.

**2.1 Heat Quantity**

The quantity, or heat content, is a measure of how much energy is contained in a waste heat stream, while quality is a measure of the usefulness of the waste heat. The quantity of waste heat contained in a waste stream is a function of both the temperature and the mass flow rate of the stream.

**2.2 Waste Heat Temperature/Quality**

The waste heat temperature is a key factor determining waste heat recovery feasibility. Waste heat temperatures can vary significantly, with cooling returns having low temperatures around 100 200°F [40 90°C] and glass melting furnaces having flue temperatures above 2,400°F [1,320°C]. In order to enable heat transfer and recovery, it is necessary that the waste heat source temperature is higher than the heat sink temperature. Moreover, the magnitude of the temperature difference between the heat source and sink is an important determinant of waste heat’s utility or “quality”.

**2.3. Waste Stream Composition**

Although chemical compositions do not directly influence the quality or quantity of the available heat (unless it has some fuel value), the composition of the stream affects the recovery process and material selection. The composition and phase of waste heat streams will determine factors such as thermal conductivity and heat capacity, which will impact heat exchanger effectiveness. Meanwhile, the process specific chemical makeup of off gases will have an important impact on heat exchanger designs, material constraints, and costs.

**2.4. Minimum Allowable Temperature**

The minimum allowable temperature for waste streams is often closely connected with material corrosion problems. Minimum exhaust temperatures may also be constrained by process related chemicals in the exhaust stream; for example, sulphates in exhaust gases from glass melting furnaces will deposit on heat exchanger surfaces at temperatures below about 510°F [270°C].

### 3. LITERATURE REVIEW

Zhongyi Su et al. [1] carried out the case study on the waste energy utilization in industries at China. He has carried out the analysis on the different industrial processes and finding out huge data for used of organic waste again in the industries. The conclusion of the study shows that reusing the potential wastes for the production is feasible. Liang-Chen Wang, et al. [2] carried out the analysis on the reusability of the energy from the exhaust gas calciner for production of carbon. In this study the analysis of exhaust is done or production of carbon with used of calciner. The present study aims to develop this method and a combustion model. To demonstrate the correctness of the method and the model, based on the data collected from the working calciners, the energy utilization ratio of a calciner with power of 1250 kW is analyzed. Rakesh Jain et al. [3] Carried out the performance improvement of a boiler through waste heat recovery from an air conditioning unit. In this study the heat from the air conditioning unit of the boiler is used for heating the feed water in boiler. The results of the study concluded that efficiency of Boiler will increase from 76.33% to 76.53%. Satish K. Maurya, [4] carried out the work on the analytical study on the waste heat recovery Combined Ejector and Vapour Compression Refrigeration System. The key advantage of the combined plant is the Financial and economical aspects also justify the heat recovery as in most of the cases as in most of the cases returns in term of savings are much greater than the investment costs.

R. Loganathan et al. [5] Carried out the waste heat recovery steam generator in sponge iron plant. The waste heat in plant is utilized gas cooler. The results of the study concluded that around annual savings will come around 198.79 lakhs which is more than the boiler cost approximate 180 lakhs. S. Umamaheswari et al [6] carried out the research work on the efficient way to generate captive power through Waste Heat Recovery (WHR) to meet out of the needs of Iron and Steel Industries has been discussed. Captive power plants have reported that the generation costs competitive with grid power. Yogendra Saidawat, et al [7] carried out the research work on the power generation from the waste heat extracted through clinker production in the cement industry. This study includes the power generation calculation for a cement plant and the different methodologies (cycles) used to generate power. Waste heat power generation has a wide scope in future to reduce carbon emissions and to optimize resources as well as energy savings.

### 4. PROPOSED RESEARCH WORK

The study is carried out on the research based on the waste heat recovery. The based literature study is implemented for developing the proposed research work. The proposed research work aims for developing the waste recovery system for the steel plant. The fig.1.1 shows the proposed research study model. The waste gases are utilizing for warming of firing oil so that the efficiency can be improves up to certain. In this research work the blowing air also used in order provided the sufficient air flow for burning of fuel.

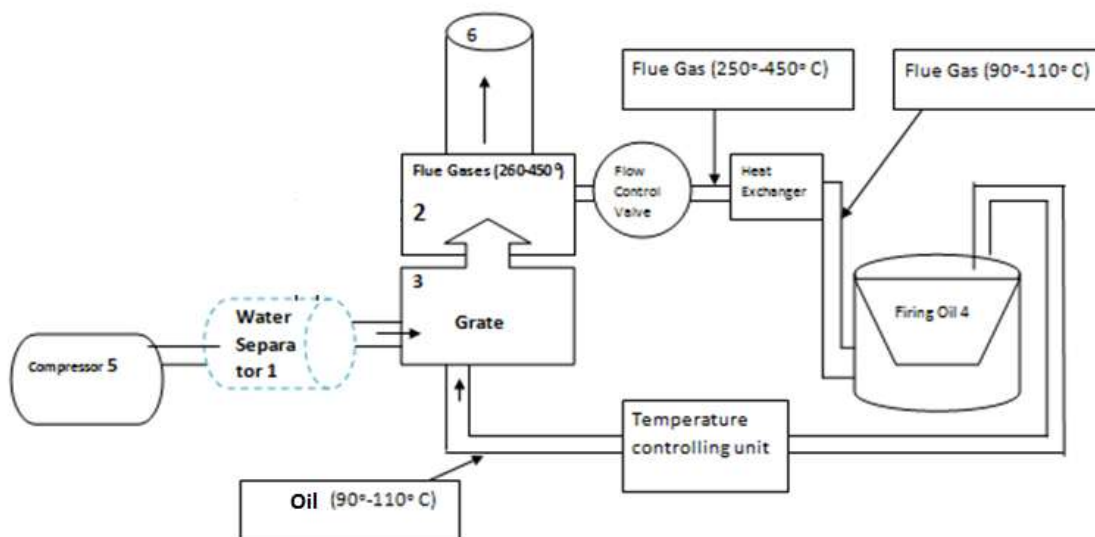

## **5. CONCLUSION**

Recovering Waste heat is the need of the day for the industries of developing countries. Extent of literature available shows a continuously increasing interest of researchers, managements and engineers in recovering the heat. Many big industrial plants have already realized the importance of heat recovery and they are effectively utilizing it in one or other way. Efforts are being done to improve the recovery efficiencies by using the latest technological advancements and optimization methods.

## **REFERENCES**

- [1] Zhongyi Su, Analysis of energy utilization and waste in China's processing industry based on a case study, The 7th International Conference on Applied Energy – ICAE2015, Energy Procedia 75 (2015 ) 572 – 577.
- [2] Liang-Chen Wang, Analysis of the reusability of the energy of the exhaust gas from the calciner for the production of carbon, Int.J. Energy Science Direct Energy 78 (2014) 439e450.
- [3] Rakesh Jain, Performance Improvement of a Boiler through Waste Heat Recovery from an Air Conditioning Unit, International Journal of Innovative Research in Science, Engineering and Technology Vol. 2, Issue 2, February 2013.
- [4] Satish K. Maurya, carried , analytical study on the waste heat recovery Combined Ejector And Vapour Compression Refrigeration System, International Journal of Engineering Sciences & Research Technology [1422-1425].
- [5] R. Loganathan, waste heat recovery steam generator in sponge iron plant, The SIJ Transactions on Industrial, Financial & Business Management (IFBM), Vol. 1, No. 1, March-April 2013, ISSN: 2321 – 242X.
- [6] Sarah Broberg Viklund, Technologies for utilization of industrial excess heat: Potentials for energy recovery and CO2 emission reduction, Energy Conversion and Management, (77), 369-379.
- [7] S.Umamaheswari, Growing Trend of Process off Gas and Waste Heat Recovery in Captive Power Generation, International Journal Of Scientific Research, Volume : 2 | Issue : 11 | November 2013 • ISSN No 2277 – 8179.
- [8] Yogendra Saidawat, Power Generation From Waste Heat Extracted Through Clinker Production In Cement Industry, International Journal in IT and Engineering, Vol.03 Issue-06, (June, 2015) ISSN: 2321-1776.